

---

**The Integrated Approach of Marketing Communications and its Impact on Tourism  
Marketing in Sulaimani Governorate**

Salar Sarhad Khaleefa Younes<sup>1</sup>, Mansour Irandoost<sup>2\*</sup>, Reza Shafei<sup>3</sup>

1. Ph.D. student, Department of Management, Sanandaj Branch, Islamic Azad University, Sanandaj, Iran.
  2. Assistant Professor, Department of Management, Sanandaj Branch, Islamic Azad University, Sanandaj, Iran. (Corresponding Author).
  3. Associate Professor, Faculty of Humanities and Social Sciences, University of Kurdistan, Iran.
- 

**Article history:**

Received date: 2022/06/02

Review date: 2022/08/13

Accepted date: 2022/08/24

---

**Keywords:**

Marketing Communications, Tourism  
Marketing, Sulaimani Governorate

**Purpose:** Marketing communications allow companies to link their brands to other people, places, events, brands, experiences, feelings, and things. They can contribute to brand equity—by establishing the brand in memory and creating a brand image—as well as drive sales and even affect shareholder value.

**Methodology:** This study aimed to investigate the integrated approach of marketing communications and its impact on tourism marketing in Sulaimani Governorate. For the current study, an analytical descriptive technique employed to match the nature and circumstances of gathering reliable academic descriptions of the phenomenon's status quo while making initial assumptions. The sample size used for the study was 252 employees from the population selected at tourism organizations. The researcher used a range of statistical methods using the SPSS program and Amos Program in order to analysis data. The study showed that integrated marketing communications have become one of the most important factors on which various tourism companies rely to attract tourists, in line with the development in the surrounding environment, the aspirations of tourists and changes in the ways they deal with tourism programs. Integrated Marketing Communications is the link between tourism institutions and their target audience of tourists. Where the tourism activity is based on the role of integrated marketing communications in introducing tourists to the tourism potentials and potentials that the region enjoys.

**Findings:** The results showed that there are no significant statistically differences among the researched organizations towards the study variable according to the difference in all their personal characteristics: gender, age, academic qualification, and years of experience.

**Conclusion:** The results of the statistical analysis of the field side showed that more than half of the respondents in the surveyed tourism companies in the city of Sulaymaniyah in the Kurdistan Region of Iraq are males compared to females.

---

**Please cite this article as:** Sarhad Khaleefa Younes S, Irandoost M, Shafei R. (2022). The Integrated Approach of Marketing Communications and its Impact on Tourism Marketing in Sulaimani Governorate, *Iranian Journal of Educational Sociology*, 5(3): 270-280.

---

\* Corresponding Author: [irandoost.m@iausdj.ac.ir](mailto:irandoost.m@iausdj.ac.ir)

## 1. Introduction

As an academic field, Integrated marketing communication (IMC) attracted marketing and management scholars' interest and is considered as "one of the most influential marketing management frameworks during the last twenty years" (Kitchen, 2015). The IMC research area has long been characterized by a vivid theoretical debate and most extant research has focused on definitional issues. Both the academia and the professional arena suggest that IMC research moved from a narrow-focus approach centred on marketing communications to a broader organizational perspective. Likewise, while early conceptualizations (Raman and Naik, 2004) clearly confine IMC to marketing communications mix and planning, most recent publications (Kliatchko and Schultz, 2014; Vernuccio and Ceccotti, 2015; Tafesse and Kitchen, 2017; Porcu et al., 2017; Luxton et al., 2017) point out that a firm-wide approach should be taken to conceptualize IMC to highlight that IMC involves the whole organization. In this regard, for Luxton et al. (2017) IMC is positioned as "a firm-wide market relating deployment mechanism that enables the optimization of communication approaches to achieve superior communication effectiveness".

The relevant role of IMC in the international tourism has been highlighted in previous studies (Pizam and Holcomb, 2008; Pike, 2008). In this regard, several scholars in the tourism management field (Pike, 2008; Clarke, 2009; Dinnie et al., 2010) have called for more research on IMC applied in the tourism sector. For example, (Ford & Peeper, 2008) argued that "one of the greatest marketing challenges faced by DMOs is stimulating a coordinated approach among all those stakeholders who have a vested interest in, and will come into contact with, the target visitors". A comprehensive literature review revealed that only a few empirical studies on IMC have been undertaken in the tourism sector (Elliott and Boshoff, 2008; Wang et al., 2009; Dinnie et al., 2010; Ortega et al., 2015).

More importantly, as mentioned earlier, in previous studies IMC has been assessed as the coordination of marketing communications, taking the narrow-focused approach described earlier and several authors have called for more research efforts to look into the role of firm-wide IMC in the tourism industry. In addition, while the majority of the extant IMC literature has taken a supply-side approach, only three of the IMC studies applied to the tourism sector have taken such approach (Elliott and Boshoff, 2008; Dinnie et al., 2010; Šerić and Saura, 2011), most of them based on a consumer approach. Elliott and Boshoff (2008), who focused their research on the effect of specific orientations on the successful implementation of IMC in small-sized tourism businesses in South Africa, suggested that the importance of IMC is crucial to attract and retain customers and enables small businesses to achieve higher revenues. Dinnie et al. (2010) pointed out that IMC plays a key role in nation branding strategy due to the fact that this pursues multiple objectives and addresses a diverse range of stakeholders. More interestingly, Šerić and Saura (2011) opened the way for IMC research within the tourism industry via a research survey conducted among hotel managers of top-quality hotels in Dalmatia (Croatia). In their study, they found that, while the application of Information and Communication Technologies and the hotel category were positively related, the IMC level decreased with the increase of the hotel category. In a number of subsequent research pieces, Šerić and colleagues (Šerić et al., 2013, 2014; Šerić, 2017) have opted for taking a customer perspective and contributed significantly to pave the way for the development of a more solid body of knowledge on the IMC application and performance in the hospitality industry.

Accordingly, our study seeks to respond to this call for a more holistic perspective to analyze IMC and causal factors on IMC and its impact on performance by taking a supply-side approach. With these premises in mind, this study formulates a theoretical model aiming to demonstrate that firm-wide IMC represents a key antecedent of market performance within the tourism sector. To validate the proposed model, the Sulaimani city has been selected as a suitable context, given the fact that Sulaimani is among the top tourist destinations at Iraq, with a strong tourism infrastructure, thus providing researchers with a good sphere of study in terms of the generalize ability of the results.

Hypotheses of the Study

The perspectives of respondents in the researched organizations in Sulaymaniyah governorate differ towards describing the variables of the current study.

The importance of the study variable and their dimensions vary according to the nature of dependence on them by researched organizations.

There are significant statistically significant differences among the researched organizations towards the variable of the study according to the difference in all their personal characteristics: gender, age, academic qualification, and years of experience.

There are significant differences for the use of the study variable Integrated Marketing Communications at the level of the surveyed Tourism Companies.

## 2. Methodology

For the current study, an analytical descriptive technique employed to match the nature and circumstances of gathering reliable academic descriptions of the phenomenon's status quo while making initial assumptions. The population consisted of all administrative staff of Tourism Companies in Sulaimany city Iraqi Kurdistan Region. To achieve the research goals, a random sample of 300 employees was selected where the study questionnaire was distributed to them, while the responded forms were 257 and 5 forms were ignored. The sample size used for the study was (252) employees from the population selected at tourism organizations.

This study relied on two types of methods to collect data and information. Firstly, secondary data was acquired that the researchers sought to cover this aspect of the study using available sources that dealt with the subject of the study such as books, articles, studies and university thesis'. Secondly, primary data based on the survey questionnaire was collected in order to complete the practical aspect of the study. The questionnaire was designed to serve the study objectives and hypotheses, using the five value Likert scale (strongly disagree, disagree, uncertain, agree, strongly agree) with the weights (1, 2, 3, 4, 5) respectively.

Secondary data, which include both qualitative and quantitative information, are generally employed in descriptive and explanatory research. Saving time and money is a benefit of using secondary data. However, it's possible that the drawbacks were gathered for a cause that does not align with the goals of the current study, and they can be difficult to access in cases where they were gathered for commercial reasons. Books, articles, and journals were some of the secondary data sources used in relation to the topic that are given in the references section. These gave the researcher the means to acquire additional knowledge about the issue. Surveys and semi-structured interviews were used to obtain the primary data, which are data that are being collected for the first time:

For Qualitative Data Collection, Data gathered from the semi-structured interviews were first transcribed, and then coded in line with the objectives of this research. And for Quantitative Data Collection, By creating and distributing a questionnaire, a quantitative research approach used in this study. It is a sort of research that is clarifying phenomena by gathering numerical data that are examined using mathematically based method" is the definition of quantitative research. Quantitative research "collects numerical data through mathematically based method." Testing preset hypotheses and producing generalizing results are the goals

Quantitative approach has been full adopted in this study in collection of primary and secondary data. Consequently a quantitative method to gather and produce the evidence gathered from the questionnaires is administrated. In addition, questionnaire considered to be suitable due to the population of this study being not easy to be quantified. As well as, five point Likert scale administrated and all questions are in shape of close ended questions.

The researcher used a range of statistical methods using the SPSS program and Amos Program in order to analysis data such as the mean and standard deviation to identify the reactions of the study sample to the study variables included in the questionnaire.

## 3. Findings

Table 1 shows the results measurement of reliability through alpha-Cronbach method.

**Table 1.** Reliability measurement through alpha-Cronbach method.

Variable	Dimensions	Number Questions	Of	Coefficient Value
<b>Integrated Marketing Communications (IMC)</b>	Advertising (Adv.)	9		0.880
	Personal Selling (PS)	7		0.759
	Stimulate Sales (SS)	7		0.900
	Public Relations (PR)	7		0.882
	Direct marketing (DM)	7		0.902
<b>Integrated Marketing Communications</b>		<b>37</b>		<b>0.964</b>

**Source:** Prepared by the researcher through the results of the SPSS statistical program.

As a result, the research criteria have fulfilled the condition of apparent validity, content validity, and measurement of reliability before distributing the questionnaire to the sample.

In order to identify the nature of the data and the extent to which they follow a normal distribution, the test was carried out based on the values of (Skewness, Kurtosis), which indicate that the acceptable value for it is (-1.96, + 1.96). From the data, it is clear that the values of both (Skewness, Kurtosis) are within the acceptance region. In other words, it means that the data follow a normal distribution, and then parametric statistics tests can be adopted in the next steps of statistical analysis.

Based on the results of testing the conditions for applying parametric or non-parametric tests, it was found that the data of the study met the two conditions, allowing the application of parametric tests in testing the hypotheses of the current study.

The formative construction of the Integrated Marketing Communications (IMC) variable scale consists of five dimensions, and to determine the items that belong to this variable or that do not belong to it, the researcher conducted an exploratory factor analysis test. Exploratory factor analysis results presented in Table 2.

**Table 2.** Exploratory Factor Analysis Results.

The dimension	Questions	Value	Values decision	The dimension	Questions	Value	Values decision
<b>Advertising</b>	Adv1	.796	Featured	<b>Stimulate Sales</b>	SS1	.769	Featured
	Adv2	.738	Featured		SS2	.618	Featured
	Adv3	.661	Featured		SS3	.632	Featured
	Adv4	.794	Featured		SS4	.778	Featured
	Adv5	.733	Featured		SS5	.671	Featured
	Adv6	.668	Featured		SS6	.643	Featured
	Adv7	.680	Featured		SS7	.759	Featured
	Adv8	.652	Featured	<b>Public Relations</b>	PR1	.705	Featured
	Adv9	.693	Featured		PR2	.564	Featured
<b>Personal Selling</b>	PS1	.674	Featured		PR3	.668	Featured
	PS2	.689	Featured		PR4	.604	Featured
	PS3	.687	Featured	PR5	.660	Featured	
	PS4	.644	Featured	PR6	.717	Featured	
	PS5	.678	Featured	PR7	.614	Featured	
	PS6	.696	Featured	<b>Direct marketing</b>	DM1	.711	Featured
	PS7	.701	Featured		DM2	.771	Featured
-	-	-	DM3		.687	Featured	
-	-	-	DM4		.750	Featured	
-	-	-	DM5		.679	Featured	
-	-	-	DM6		.718	Featured	
-	-	-	DM7		.636	Featured	

**Source:** Prepared by the researcher based on SPSS program outputs (N=252)

It is clear from the Figure 1 that all the estimates of the standard parameters of the questions of the Integrated Marketing Communications (IMC) exceeded the percentage of (0.40). They are the ratios shown on the arrows that link the sub-dimensions with their questions, and all of them were significant ratios. Because when following the values of the critical ratio (CR) shown in the Table 3, it turns out that it is greater than (2.56) at the level of significance (0.01). This indicates the feasibility and validity of these parameters. As for the indicators of model conformity, the results showed, as is evident in the structural model, that all of them fulfilled the acceptance rule assigned to them. Thus, the structural model has achieved a high level of conformity without the need for any suggested modification indicators. Which confirms that the Integrated Marketing Communications (IMC) variable is measured by (37) questions evenly distributed over five interrelated dimensions, which are: Advertising (Adv), Personal Selling (PS), Stimulate Sales, (SS), Public Relations (PR), and Direct marketing (DM).

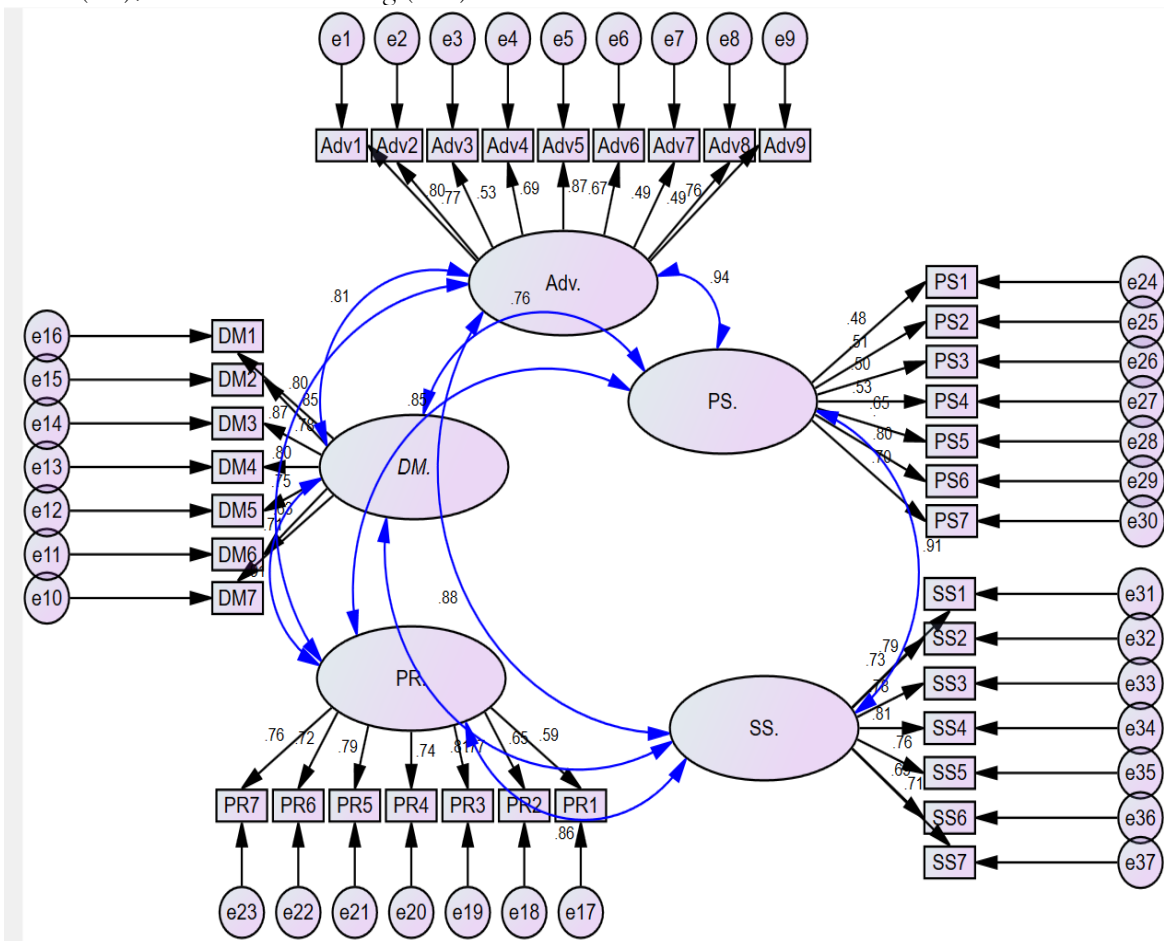

**Figure 1.** Confirmatory Factor Analysis of Integrated Marketing Communications (IMC) scale (Source: Amos V.24 program outputs).

For the indicators of model conformity, the results showed, as is evident in the structural model, that all of them met the acceptance rule assigned to them, as follows:

- The ratio between the CMIN values and the degrees of freedom df (4.297).
- CFI Value (.911).
- IFI Value (.913).
- TLI Value (.909).

- RMSEA Value (0.049).
- Chi-square Value = 2659.534.
- Probability level = 0.000

**Table 3.** Values of parameter estimates, standard error, critical ratio, and level of significance of the Integrated Marketing Communications (IMC) scale.

Questions	Path	Dimensions	Estimate	S.E.	C.R.	P value
Adv1	<---	Adv.	1.000			
Adv2	<---	Adv.	.925	.066	13.927	0.000
Adv3	<---	Adv.	.655	.077	8.536	0.000
Adv4	<---	Adv.	.814	.070	11.674	0.000
Adv5	<---	Adv.	1.086	.068	15.935	0.000
Adv6	<---	Adv.	.805	.070	11.446	0.000
Adv7	<---	Adv.	.560	.071	7.920	0.000
Adv8	<---	Adv.	.521	.068	7.708	0.000
Adv9	<---	Adv.	.912	.069	13.215	0.000
DM7	<---	DM.	1.000			
DM6	<---	DM.	1.046	.111	9.464	0.000
DM5	<---	DM.	1.391	.123	11.276	0.000
DM4	<---	DM.	1.216	.101	12.045	0.000
DM3	<---	DM.	1.175	.099	11.823	0.000
DM2	<---	DM.	1.257	.098	12.835	0.000
DM1	<---	DM.	1.204	.099	12.178	0.000
PR1	<---	PR.	1.000			
PR2	<---	PR.	1.091	.128	8.555	0.000
PR3	<---	PR.	1.277	.134	9.544	0.000
PR4	<---	PR.	1.381	.149	9.276	0.000
PR5	<---	PR.	1.424	.148	9.609	0.000
PR6	<---	PR.	1.343	.146	9.219	0.000
PR7	<---	PR.	1.338	.143	9.357	0.000
PS1	<---	PS.	1.000			
PS2	<---	PS.	1.094	.177	6.168	0.000
PS3	<---	PS.	1.069	.176	6.088	0.000
PS4	<---	PS.	1.065	.170	6.279	0.000
PS5	<---	PS.	.954	.155	6.288	0.000
PS6	<---	PS.	1.720	.238	7.231	0.000
PS7	<---	PS.	1.527	.223	6.854	0.000
SS1	<---	SS.	1.000			
SS2	<---	SS.	.976	.078	12.510	0.000
SS3	<---	SS.	.987	.074	13.370	0.000
SS4	<---	SS.	1.074	.077	13.875	0.000
SS5	<---	SS.	.973	.075	12.901	0.000
SS6	<---	SS.	.976	.085	11.515	0.000
SS7	<---	SS.	.982	.083	11.809	0.000

**Source:** Prepared by the researcher based on the outputs of the program (Amos V.24).

Personal information of the study sample presented in Table 4.

**Table 4.** Personal information of the study sample.

	Categories	Frequency	Percent
Sex	Male	157	62.3
	Female	95	37.7
Age	20-30	55	21.8
	31-40	122	48.4
	41-50	47	18.7
	51-60	28	11.1
Academic Qualification	High Scholl	3	1.2
	Diploma	70	27.8
	BSc	149	59.1
	High diploma	13	5.2
	Msc or PhD.	17	6.7
Years of Experience	less than 5	64	25.4
	5-10	119	47.2
	more than 10	69	27.4
<b>Total</b>		<b>252</b>	<b>100.0</b>

**Source:** prepared by the researcher from the results of SPSS statistical analysis.

The perspectives of respondents in the researched organizations in Sulaymaniyah governorate differ towards describing the variables of the current study.

Direct Marketing (DM) Questions Description presented in Table 5. Based on the results of Table 5, the first main hypothesis that states “the perspectives of respondents in the researched organizations in Sulaymaniyah governorate differ towards describing the variables of the current study)” is accepted.

**Table 5.** Direct Marketing (DM) Questions Description.

Questions	I totally disagree		I disagree		I have no idea		I agree		I totally agree		Mean	Standard Deviation	Agreement Rate
	%	F.	%	F.	%	F.	%	F.	%	F.			
DM1	3.6	9	7.1	18	12.7	32	54.4	137	22.2	56	3.85	.968	77
DM2	3.6	9	3.6	9	18.3	46	48.0	121	26.6	67	3.90	.952	78
DM3	3.2	8	3.2	8	17.5	44	40.9	103	35.3	89	4.02	.972	80.4
DM4	4.0	10	4.0	10	23.0	58	43.7	110	25.4	64	3.83	.987	76.6
DM5	7.1	18	14.3	36	21.8	55	33.3	84	23.4	59	3.52	1.199	70.4
DM6	3.6	9	11.9	30	26.2	66	34.9	88	23.4	59	3.63	1.077	72.6
DM7	2.4	6	4.4	11	11.9	30	48.4	122	32.9	83	4.05	.915	81
Total											3.82	1.01	76.57

**Source:** prepared by the researcher from the results of SPSS statistical analysis.

The importance of the study variable and their dimensions vary according to the nature of dependence on them by researched organizations.

Importance of Integrated Marketing Communications (IMC) Dimensions provide in Table 6. Based on the results of Table 6, the second main hypothesis is accepted that states the importance of the study variable and their dimensions vary according to the nature of dependence on them by researched organizations.

**Table 6.** Importance of Integrated Marketing Communications (IMC) Dimensions.

The Variable and its Dimensions	Mean	Standard Deviation	Coefficient of Variation %	Significance Level
Advertising (Adv.)	3.85	0.992	25.76	2
Personal Selling (PS)	3.86	0.955	24.74	1
Stimulate Sales (SS)	3.71	1.007	27.14	5
Public Relations (PR)	3.81	0.994	26.08	4
Direct marketing (DM)	3.82	1.01	26.43	3

<b>Integrated Marketing Communications (IMC)</b>	3.812	0.9916	26.03	-
--	-------	--------	-------	---

**Source:** prepared by the researcher from the results of SPSS statistical analysis.

There are significant statistically significant differences among the researched organizations towards the variable of the study according to the difference in all their personal characteristics: gender, age, academic qualification, and years of experience.

The results of differences according to years of experience feature provided in Table 7. Based on the results of analyzing the previous differences between the study variable according to the personal characteristics of the study sample, it was found that there were no significant differences in the Integrated Marketing Communications (IMC) which could be the source of the personal characteristics of the responding individuals. Accordingly, the third main hypothesis is rejected, which states that there are significant statistically significant differences among the researched organizations towards the study variable according to the difference in all their personal characteristics: gender, age, academic qualification, and years of experience, and acceptance of the alternative hypothesis which states that (there are no significant statistically significant differences among the researched organizations towards the study variable according to the difference in all their personal characteristics: gender, age, academic qualification, and years of experience).

**Table 7.** The differences according to years of experience feature.

	Sum of Squares	Df	Mean Square	F	Sig.
Between Groups	1.232	2	.616	1.446	.238
Within Groups	106.065	249	.426		
Total	107.297	251			

**Source:** prepared by the researcher from the results of SPSS statistical analysis.

There are significant differences for the use of the study variable Integrated Marketing Communications at the level of the surveyed Tourism Companies.

The results of discriminant function among the surveyed Tourism Companies according to Integrated Marketing Communications presented in Table 8. According to the results, the fourth hypothesis was accepted, which states that there are significant differences for the use of the study variable Integrated Marketing Communications at the level of the surveyed Tourism Companies.

**Table 8.** The Discriminant function among the surveyed Tourism Companies according to Integrated Marketing Communications.

Tourism Companies	Discriminant Function	Rank
Gold Air Comp.	0.593	1
Moonline Comp.	0.497	2
Azmar Comp	0.123	3
Alt Air Comp.	0.066	4
Shabaq Comp.	0.017	5
Merka Travel Comp.	0.008	6
Rovar Comp.	-0.002	7
Meran Comp.	-0.140	8
Alaska Holiday Comp.	-0.170	9
Al-Tawst Comp.	-0.261	10
Aroz Air Comp.	-0.503	11
Wilks' Lambda	0.953	
Chi-square	11.800	
P-Value	0.000	

**Source:** prepared by the researcher from the results of SPSS statistical analysis.



#### 4. Discussion

The results of the statistical analysis of the field side showed that more than half of the respondents in the surveyed tourism companies in the city of Sulaymaniyah in the Kurdistan Region of Iraq are males compared to females. Based on the results, the largest percentage of the study sample according to age was young in the age while the oldest recorded the lowest percentage. The results of the statistical analysis found that more than half of the study sample in the surveyed tourism companies are holders of bachelor's degrees, and in the second rank came diploma holders, and these characteristics are compatible with the requirements of combining academic knowledge and field experience in tourism area. In addition, the practical experiences of the study sample in the surveyed tourism companies in the tourism field were concentrated within the medium practical expertise. This enhances the ability of these tourism companies to improve the quality of tourism services provided to tourists, due to their having sufficient intellectual maturity, which makes them more able to employ the mechanisms and requirements of integrated marketing.

The result showed that there was a difference in the respondents' perspectives regarding the description of each of the Integrated Marketing Communications dimensions, as the highest percentage of agreement was in the Personal Selling dimension. This is because the surveyed tourism companies reinforce positive expectations and beliefs that individuals hold towards individuals who perform this task and by relying on each other in the success of these practices. Based on the results, Advertising comes after Personal Selling in the respondents' perspectives regarding the description of each of the Integrated Marketing Communications dimensions. This is because the surveyed tourism companies provide sufficient information about the tourist services. The respondents' perspectives showed that the surveyed tourism companies aim to achieve integrated marketing communications and enhance their performance levels, within the mechanism of applying a regulatory context characterized by honesty, merit, trust, honor, procedures and work practices in tourism activities.

The surveyed tourism company uses the integrated marketing communication tools effectively, and the effectiveness of these tools varies in terms of level. The results showed that personal selling, advertising, direct marketing, public relations, and stimulate sales are the most effective in delivering the message to the customer, the more effective it is that the customer prefers the company that launches promotional campaigns that include incentive prizes or the presence of discounts in the prices. The study found that the integrated marketing communication play a major role in building the customer's confidence and enhancing his/her commitment, and the presence of a specialized cadre of workers in the surveyed tourism companies on the front line has contributed to influencing the achievement of a relationship between the customer and the company in the direction of developing loyalty to it so that it becomes like a psychological link with the company.

Direct marketing's effective role in integrated marketing communication has emerged through the tourism companies' possession of knowledge and expertise about how to use the company's services, as well as their ability to communicate information to the customer. The study showed that integrated marketing communications have become one of the most important factors on which various tourism companies rely to attract tourists, in line with the development in the surrounding environment, the aspirations of tourists and changes in the ways they deal with tourism programs. The surveyed tourism companies showed their interest in communicating with the customer through public relations, and they ranked fourth in terms of relative importance. What contributed to the effectiveness of this tool was that most of the study community had good relations with other parties, which made it possible to define opportunities and manage the customer relationship.

Customer satisfaction is an important tool for measuring the marketing success of the organization in particular and its performance in general, and this is only exist through the success of the communication process for the proper flow of information from products and services. The results found that Stimulate Sales ranked fifth in terms of relative importance and was less effective compared to other tools due to providing

promotional coupons to customers to promote their services on social media platforms was not in their expectations. Integrated Marketing Communications is the link between tourism institutions and their target audience of tourists. Where the tourism activity is based on the role of integrated marketing communications in introducing tourists to the tourism potentials and potentials that the region enjoys. The results found that there are no significant statistically differences among the researched organizations towards the study variable according to the difference in all their personal characteristics: gender, age, academic qualification, and years of experience.

### **Acknowledgments**

In this research, the ethical standards including obtaining informed consent, guaranteeing privacy, confidentiality, etc. are observed, and the participants are hereby thanked.

## References

- Clarke A. (2009). Destination marketing: an integrated marketing communication approach. A book review. *Tour. Manag.* 30(1): 140–141.
- Dinnie K, Melewar TC, Seidenfuss K, Musa G. (2010). Nation branding and integrated marketing Communications: an ASEAN perspective. *Int. Mark. Rev.* 27(4): 388–403.
- Elliott RM, Boshoff C. (2008). The influence of business orientations in small tourism businesses on the success of integrated marketing communication. *Manag. Dyn. Knowl. Econ.* 17(4): 32–46.
- Ford RC, Peeper WC. (2008). Managing destination marketing organizations: The tasks, roles and responsibilities of the convention and visitor's bureau executive. ForPer Publications.
- Kitchen PJ. (2015). Integrated marketing communications: evolution, current status, future developments.
- Kliatchko JG, Schultz Don E. (2014). Twenty years of IMC: a study of CEO and CMO perspectives in the Asia-Pacific region. *Int. J. Advert.* 33(2): 373–390.
- Luxton S, Reid M, Mavondo F. (2017). IMC capability: antecedents and implications for brand performance. *European Journal of Marketing.*
- Ortega-Argilés R, McCann P. (2015). Smart specialization, regional growth and applications to European Union cohesion policy. *Regional studies.* 49(8): 1291-1302.
- Pike S. (2008). Managing Destination Marketing Organizations: The Tasks, Roles and Responsibilities of the Convention and Visitors Bureau Executive, RC Ford, WC Peeper, ForPer Publications, Orlando, Tourism Management. 28(2): 1246.
- Pizam A, Holcomb J. (2008). *International dictionary of hospitality management.* Routledge
- Porcu L, Del Barrio-Garcia S, Kitchen PJ. (2017). Measuring integrated marketing communication by taking a broad organizational approach. *European Journal of Marketing.*
- Raman K, Naik PA. (2004). Long-term profit impact of integrated marketing communications program. *Review of Marketing Science.* 2(1).
- Šerić M. (2017). Relationships between social Web, IMC and overall brand equity. *European Journal of Marketing.*
- Šerić M, Saura IG. (2011). Análisis de los hoteles de altacategoría de croacia desde el enfoque hotel-huésped. *Investigaciones Europeas de Dirección y Economía de la Empresa.* 17(3): 127-149.
- Šerić M, Gil-Saura I, Molla-Descals A. (2013). Loyalty in high-quality hotels of Croatia: from marketing initiatives to customer brand loyalty creation. *Journal of Relationship Marketing.* 12(2): 114-140.
- Šerić M, Gil-Saura I, Ruiz-Molina ME. (2014). How can integrated marketing communications and advanced technology influence the creation of customer-based brand equity? Evidence from the hospitality industry. *International Journal of Hospitality Management.* 39: 144-156.
- Tafesse W, Kitchen PJ. (2017). IMC—an integrative review. *International Journal of Advertising.* 36(2): 210-226.
- Vernuccio M, Ceccotti F. (2015). Strategic and organizational challenges in the integrated marketing communication paradigm shift: A holistic vision. *European Management Journal.* 33(6): 438-449.
- Wang H, Ullah MM, Klaser A, Laptev I, Schmid C. (2009). Evaluation of local spatio-temporal features for action recognition.